



US008841836B2

(12) **United States Patent**
Kim et al.

(10) **Patent No.:** **US 8,841,836 B2**
(45) **Date of Patent:** **Sep. 23, 2014**

(54) **FLAT PANEL DISPLAY DEVICE, ORGANIC LIGHT EMITTING DISPLAY DEVICE AND METHOD OF MANUFACTURING FLAT PANEL DISPLAY DEVICE**

(71) Applicant: **Samsung Display Co., Ltd.**, Yongin (KR)

(72) Inventors: **Sang-Ho Kim**, Yongin (KR); **Jae-Woo Bae**, Yongin (KR); **Hun-Jung Lee**, Yongin (KR)

(73) Assignee: **Samsung Display Co., Ltd.**, Yongin, Gyeonggi-Do (KR)

(*) Notice: Subject to any disclaimer, the term of this patent is extended or adjusted under 35 U.S.C. 154(b) by 0 days.

(21) Appl. No.: **13/677,123**

(22) Filed: **Nov. 14, 2012**

(65) **Prior Publication Data**

US 2013/0285539 A1 Oct. 31, 2013

(30) **Foreign Application Priority Data**

Apr. 27, 2012 (KR) 10-2012-0044671

(51) **Int. Cl.**

H01L 51/52 (2006.01)
H05B 33/02 (2006.01)
G02B 5/30 (2006.01)
G02B 1/11 (2006.01)
H05B 33/12 (2006.01)

(52) **U.S. Cl.**

CPC **H05B 33/12** (2013.01); **G02B 5/3025** (2013.01); **G02B 1/11** (2013.01); **G02B 1/118** (2013.01)
USPC **313/504**; 313/498

(58) **Field of Classification Search**

CPC . H01L 51/5012; H01L 51/5262; H01L 27/12; H01L 27/32; H01L 51/0096; H01L 33/26; H01L 33/42; H01L 33/40; H01L 27/1218
USPC 313/498-512
See application file for complete search history.

(56) **References Cited**

U.S. PATENT DOCUMENTS

6,514,674	B1 *	2/2003	Iwasaki	430/321
6,671,016	B1	12/2003	Kim		
2004/0155846	A1 *	8/2004	Hoffman et al.	345/87
2006/0175959	A1 *	8/2006	Choong et al.	313/504
2008/0042926	A1 *	2/2008	Egi et al.	345/32
2009/0115321	A1 *	5/2009	Hayashi	313/504
2010/0123384	A1 *	5/2010	Miller et al.	313/498
2011/0164210	A1 *	7/2011	Tsuda	349/96
2012/0049206	A1 *	3/2012	Choi et al.	257/88
2012/0126688	A1 *	5/2012	Richardson et al.	313/504

FOREIGN PATENT DOCUMENTS

JP	2011-048000	A	3/2011	
KR	2001-0001104	A	1/2001	
KR	10-0754327	B1	8/2007	
KR	10-2010-0104103	A	9/2010	
WO	WO 2006125988	A1 *	11/2006 H01L 51/52

* cited by examiner

Primary Examiner — Donald Raleigh

(74) *Attorney, Agent, or Firm* — Knobbe, Martens, Olson & Bear, LLP

(57) **ABSTRACT**

A flat panel display device includes a transparent display panel including a transparent area transmitting light incident on one surface of the transparent display panel to the other surface opposite to the one surface; a first anti-reflective film which is formed over the one surface of the transparent display panel and has a moth eye structure; and a second anti-reflective film which is formed over the other surface of the transparent display panel and has a moth eye structure.

17 Claims, 5 Drawing Sheets

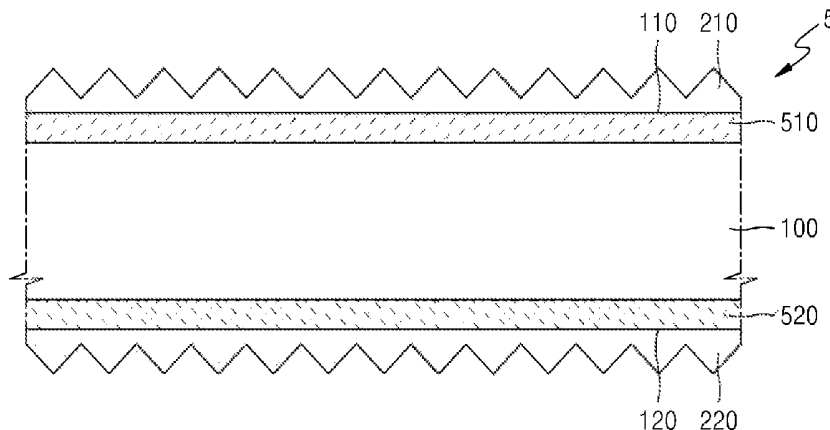

FIG. 1

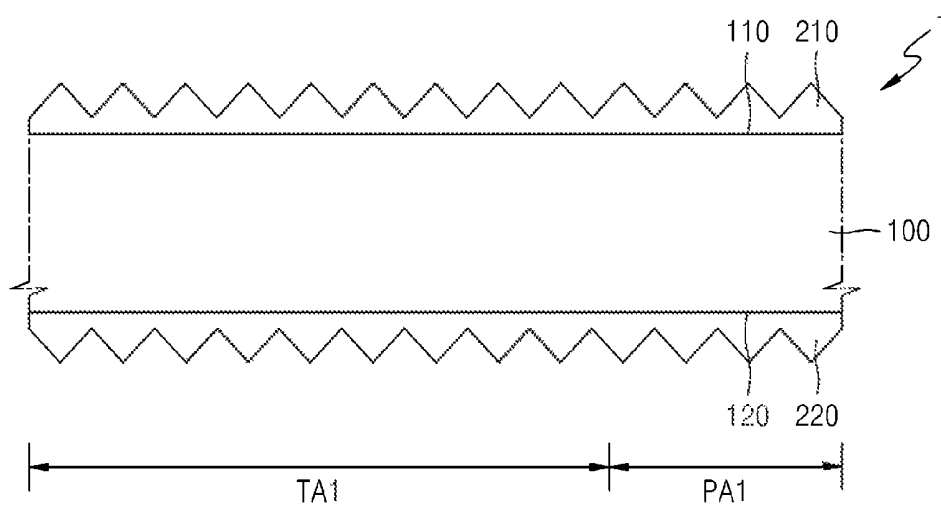

FIG. 2

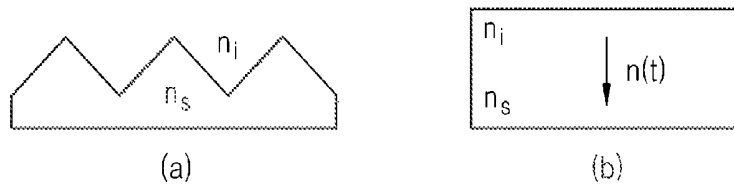

FIG. 3

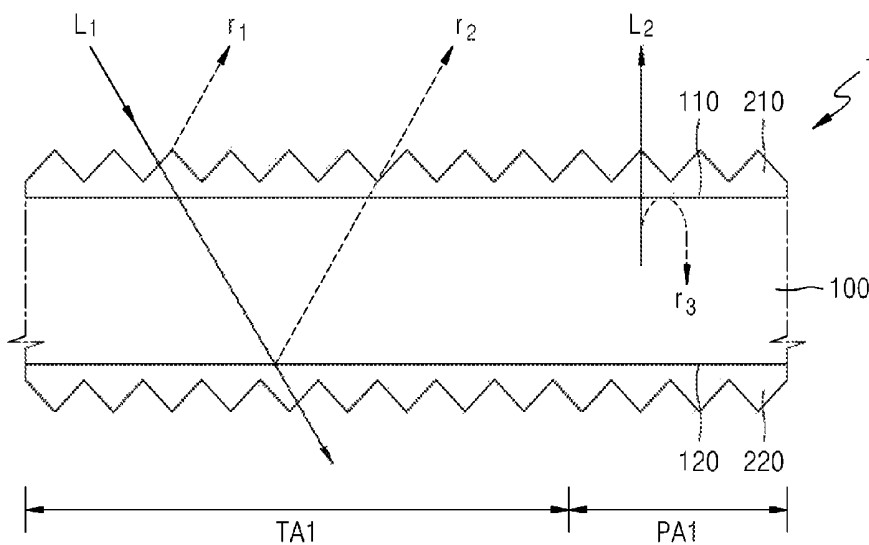

FIG. 4

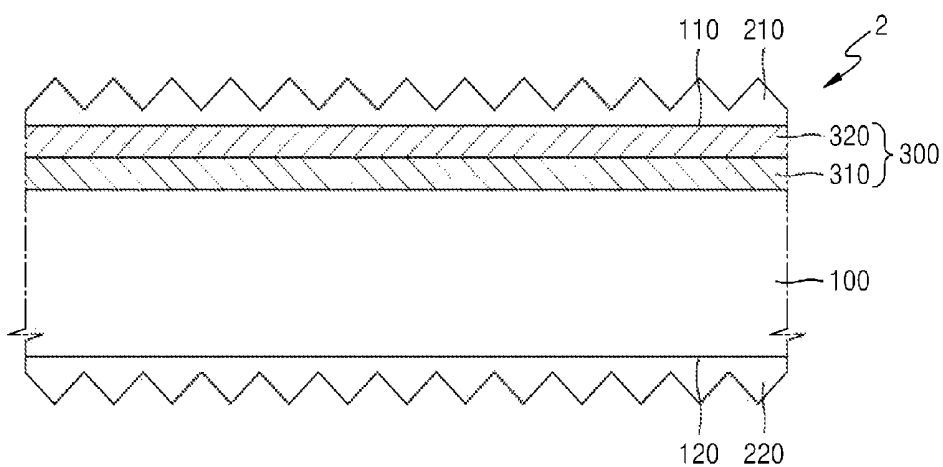

FIG. 5

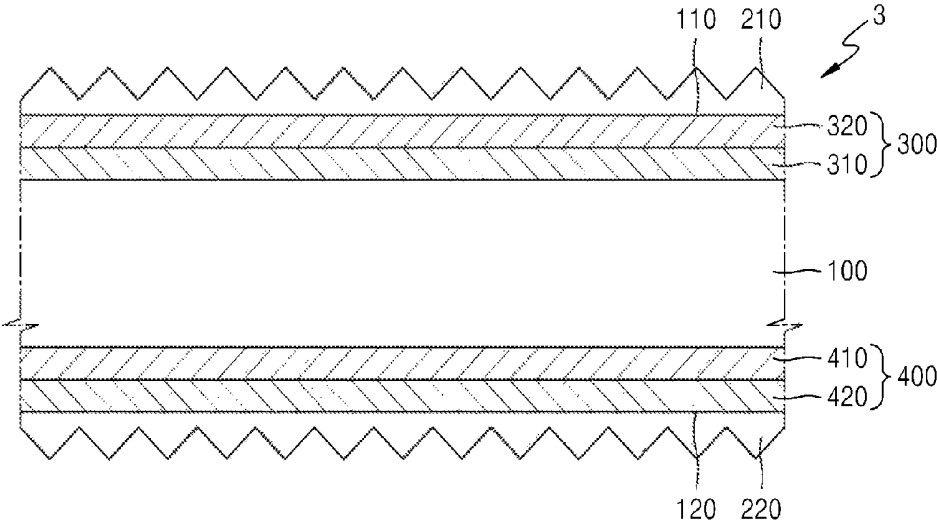

FIG. 6

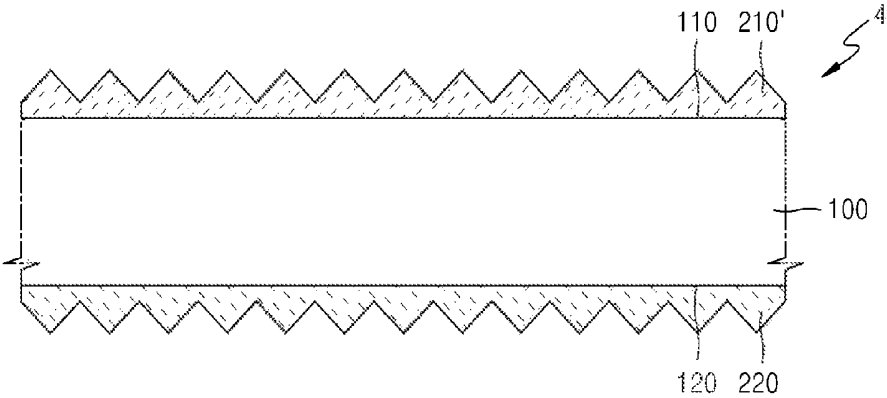

FIG. 7

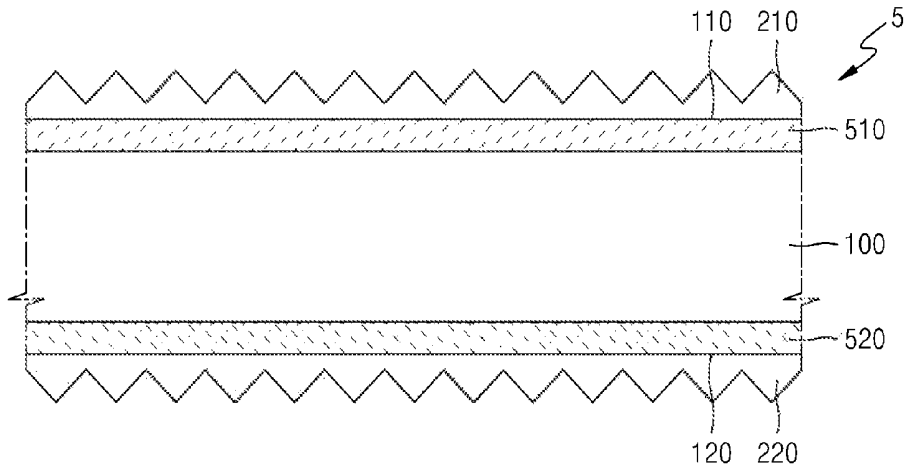

FIG. 8

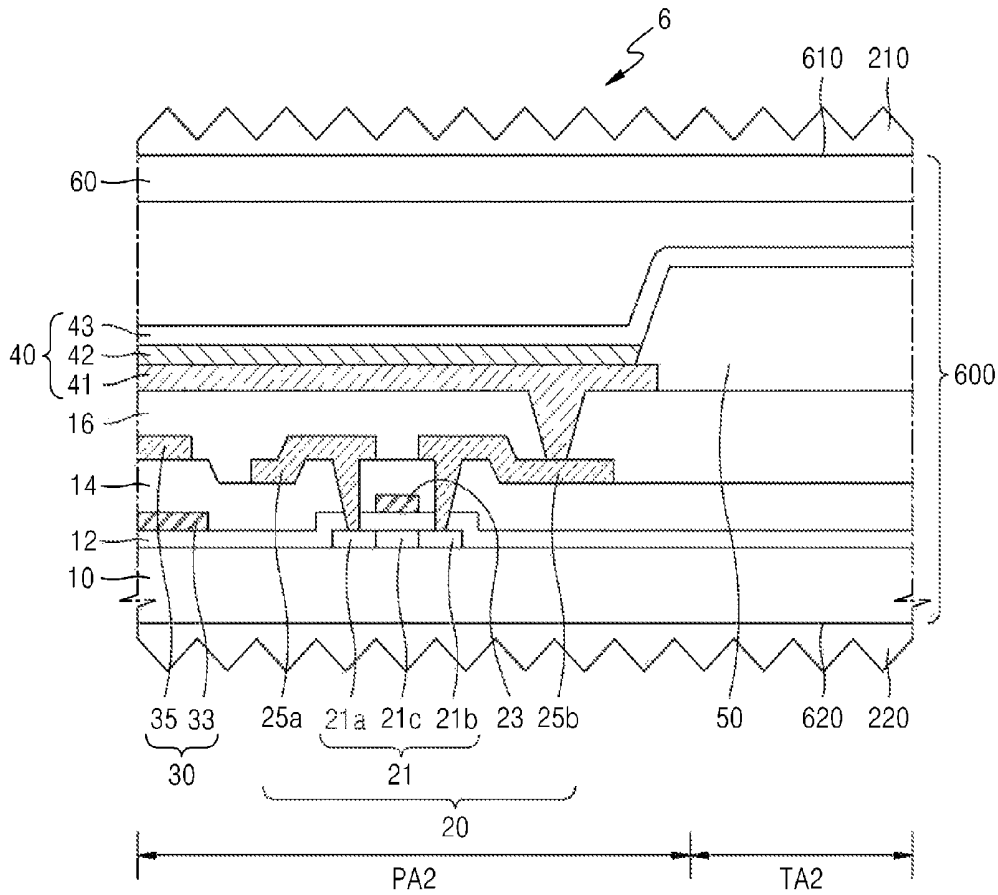

FIG. 9

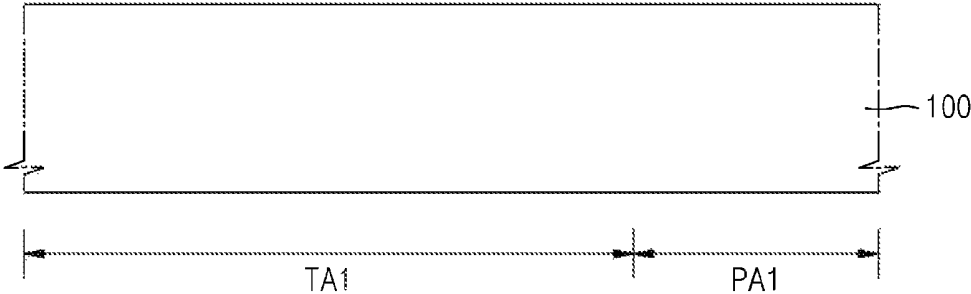

FIG. 10

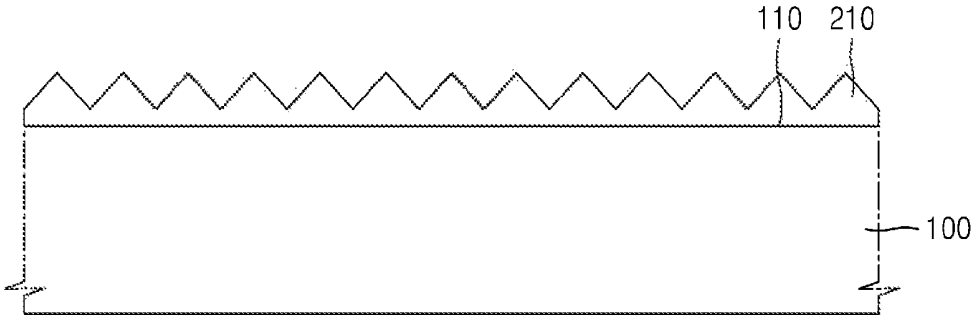
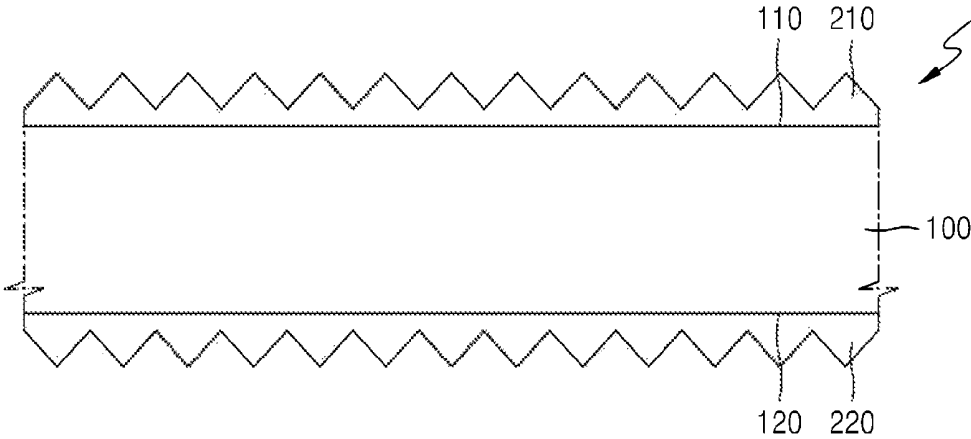

FIG. 11



**FLAT PANEL DISPLAY DEVICE, ORGANIC
LIGHT EMITTING DISPLAY DEVICE AND
METHOD OF MANUFACTURING FLAT
PANEL DISPLAY DEVICE**

CROSS-REFERENCE TO RELATED PATENT
APPLICATION

This application claims the benefit of Korean Patent Application No. 10-2012-0044671, filed on Apr. 27, 2012, in the Korean Intellectual Property Office, the disclosure of which is incorporated herein in its entirety by reference.

BACKGROUND

1. Field

The present disclosure relates to a flat panel display device, such as an organic light emitting display device, and a method of manufacturing the flat panel display device.

2. Discussion of the Related Technology

Recently, flat panel display devices that may be easily implemented in a large-area dimension, thin type, and light-weighted condition are rapidly and widely being used. Such flat panel display devices include liquid crystal displays (LCDs), plasma display panels (PDPs), or organic light emitting display devices (OLEDs).

Also, the flat panel display device may be implemented as a transparent display device including a transparent region in at least a portion of the flat panel display device.

SUMMARY

An aspect of the present invention provides a flat panel display device, such as an organic light emitting display device, and a method of manufacturing the flat panel display device, wherein the flat panel display device includes a transparent display panel having an improved bright room contrast and visibility by suppressing external light reflection.

One aspect of the present invention provides a flat panel display device including a transparent display panel which includes a transparent area configured to at least partly transmit light incident on one surface of the transparent display panel to the other surface opposite to the one surface; a first anti-reflective film which is formed over the one surface of the transparent display panel and has a moth eye structure; and a second anti-reflective film which is formed over the other surface of the transparent display panel and has a moth eye structure.

In the foregoing device, the first and second anti-reflective films may comprise a plurality of projections, each of which is in the form of a quadrangular pyramid or a circular cone.

The moth eye structure may include a plurality of projections that are respectively spaced at an interval equal to or less than the wavelength of a visible ray.

The flat panel display device may further include a first circular polarizer interposed between the transparent display panel and the first anti-reflective film.

The flat panel display device may further include a second circular polarizer interposed between the transparent display panel and the second anti-reflective film.

The flat panel display device may further include a first light-absorbing film, which is interposed between the transparent display panel and the first anti-reflective film and configured to absorb at least a portion of light having a wavelength within a range of about 350 nm to about 800 nm.

The flat panel display device may further include a second light-absorbing film, which is interposed between the trans-

parent display panel and the second anti-reflective film and configured to absorb at least a portion of light having a wavelength within a range of about 350 nm to about 800 nm.

The first anti-reflective film may include a light-absorbing dye, which absorbs at least a part of light having a wavelength within a range of about 350 nm to about 800 nm.

The second anti-reflective film may include a light-absorbing dye, which is configured to absorb at least a part of light having a wavelength within a range of about 350 nm to about 800 nm.

Another aspect of the present invention provides an organic light emitting display device including a transparent display panel which includes a transparent area configured to at least partly transmit light incident on one surface of the transparent display panel to the other surface opposite to the one surface, and at least a pixel including a pixel electrode, an organic emission layer disposed over the pixel electrode, and a counter electrode disposed over the organic emission layer; a first anti-reflective film placed over the one surface of the transparent display panel and comprising a moth eye structure; and a second anti-reflective film placed on the other surface of the transparent display panel and comprising a moth eye structure.

Still another aspect of the present invention provides a method of manufacturing a flat panel display device. The method includes providing a transparent display panel including a transparent area, which is configured to at least partly transmit light incident on one surface of the transparent display panel to the other surface opposite to the one surface; forming a first anti-reflective film over the one surface of the transparent display panel, wherein the first anti-reflective film comprises a moth eye structure; and forming a second anti-reflective film over the other surface of the transparent display panel, wherein the second anti-reflective film comprises a moth eye structure.

In the foregoing method, the forming of the first and second anti-reflective films may include forming a plurality of projections of the first and second anti-reflective films, each of the plurality of projections being in the form of a quadrangular pyramid or a circular cone.

The forming of the first and second anti-reflective films may include forming the moth eye structure including a plurality of projections that are respectively spaced at an interval equal to or less than the wavelength of the visible ray.

The method may further include forming a first circular polarizer before the forming of the first anti-reflective film.

The method may further include forming a second circular polarizer before the forming of the second anti-reflective film.

The method may further include forming a first light-absorbing film configured to absorb at least a portion of light having a wavelength within a range of about 350 nm to about 800 nm before the forming of the first anti-reflective film.

The method may further include forming a second light-absorbing film configured to absorb at least a portion of light having a wavelength within a range of about 350 nm to about 800 nm before the forming of the second anti-reflective film.

The first anti-reflective film may include a light-absorbing dye, which is configured to absorb at least a part of light having a wavelength within a range of about 350 nm to about 800 nm.

The second anti-reflective film may include a light-absorbing dye, which is configured to absorb at least a part of light having a wavelength within a range of about 350 nm to about 800 nm.

BRIEF DESCRIPTION OF THE DRAWINGS

The above and other features and advantages of the present invention will become more apparent by describing in detail embodiments thereof with reference to the attached drawings in which:

FIG. 1 is a cross-sectional view schematically illustrating a flat panel display device according to an embodiment of the present invention;

FIG. 2 shows views illustrating an example of a moth eye structure that is applied to an embodiment of the present invention;

FIG. 3 is a conceptual view schematically illustrating pathways of external light incident on and reflected from the flat panel display device of FIG. 1;

FIG. 4 is a cross-sectional view schematically illustrating a flat panel display device according to another embodiment of the present invention;

FIG. 5 is a cross-sectional view schematically illustrating a flat panel display device according to another embodiment of the present invention;

FIG. 6 is a cross-sectional view schematically illustrating a flat panel display device according to another embodiment of the present invention;

FIG. 7 is a cross-sectional view schematically illustrating a flat panel display device according to another embodiment of the present invention;

FIG. 8 is a cross-sectional view schematically illustrating an organic light emitting display device according to an embodiment of the present invention;

FIGS. 9 through 11 are cross-sectional views schematically illustrating a method of manufacturing the flat panel display device of FIG. 1 according to an embodiment of the present invention.

DETAILED DESCRIPTION OF EMBODIMENTS

Hereinafter, embodiments of the present invention will be described in detail with reference to the accompanying drawings.

Generally, a circular polarizer or an anti-reflective (AR) film may be used in order to improve contrast and visibility by suppressing reflection of external light of the transparent display device.

However, since a substrate having a high reflectivity is used in the transparent display device, the reflectivity of the external light is high and reflection may occur on a surface where the external light is transmitted through a transparent panel as well as a surface in an incident direction of the external light. Thus, the reflection of the external light may not be sufficiently reduced.

FIG. 1 is a cross-sectional view schematically illustrating a flat panel display device 1 according to an embodiment of the present invention, and FIG. 2 shows views illustrating an example of a moth eye structure that is applied to an embodiment of the present invention.

Referring to FIG. 1, the flat panel display device 1 according to an embodiment includes a transparent display panel 100 including a transparent area TA1 that can transmit light incident on one surface 110 of the transparent display panel 100 to the other surface 120 opposite to the one surface 110, a first anti-reflective film 210 disposed on the one surface 110 of the transparent display panel 100 and having a moth eye structure, and a second anti-reflective film 220 disposed on the other surface 120 of the transparent display panel 100 and having a moth eye structure.

The transparent display panel 100 includes a transparent substrate (not shown), the transparent area TA1, and a pixel area PA1 for forming an image. In embodiment, the pixel area PA1 may include a pixel of an organic emission layer or a liquid crystal cell.

The flat panel display device 1 according to an embodiment of the present invention has the first and second anti-reflective films 210 and 220 that are respectively attached on the two surfaces 110 and 120 of the transparent display panel 100. In embodiments, each of the first and second anti-reflective films 210 and 220 has a moth eye structure.

In embodiment, the moth eye structure includes a plurality of projections that are respectively spaced at an interval equal to or less than the wavelength of a visible ray, and does not reflect light regardless of an incident angle or wavelength of light. The projections may be in the form of a quadrangular pyramid or a circular cone.

Generally, when light moves from one medium to another medium with different refractive index, Fresnel reflection occurs due to a refractive index difference between the two mediums.

Referring to the views (a) and (b) of FIG. 2, when a visible ray is incident on the moth eye structure having projections spaced at an interval d equal to or less than the wavelength of the visible ray having a refractive index n_s greater than a refractive index n_i of air or the like as shown in the view (a) of FIG. 2, the incident light acts in the same manner as that of the case that the light is incident on a medium having a continuously varying refractive index from n_i to n_s as shown in the view (b) of FIG. 2. That is, the moth eye structure shown in the view (a) of FIG. 2 may be considered as equivalent to the structure shown in the view (b) of FIG. 2.

Therefore, when external light is incident on the transparent display panel 100 through the first anti-reflective film 210 having a continuously varying refractive index, Fresnel reflection does not occur, and thus the external light reflection may be effectively suppressed.

FIG. 3 is a conceptual view schematically illustrating pathways of external light incident on the flat panel display device 1 of FIG. 1 and light emitted from the flat panel display device 1 of FIG. 1.

Referring to FIG. 3, when external light L_1 is incident from the outside on the transparent area TA1 of the flat panel display device 1, a part of the external light L_1 may be reflected from an interface between the first anti-reflective film 210 having the moth eye structure and the transparent display panel 100. In embodiments, a reflectivity is r_1 . Also, the light that is not reflected therefrom but transmitted through the transparent display panel 100 may be partially reflected from an interface between the second anti-reflective film 220 having the moth eye structure and the transparent display panel 100 with a reflectivity of r_2 .

That is, the whole reflectivity of the external light is about $r_1 + r_2$ when r_1 is much smaller than transmittance of the external light L_1 . In the illustrated embodiment, the anti-reflective films have the moth eye structure as described above, and the whole reflectivity is also very small, and thus the external light reflection may be effectively suppressed.

Moreover, when light L_2 emitted from pixels of the transparent display panel 100 is emitted to the outside, a part of the light L_2 is reflected from an interface between the transparent display panel 100 and the first anti-reflective film 210 with a reflectivity of r_3 . However, the reflectivity r_3 has a very small value, and thus most of the light L_2 emitted from the pixels may be emitted without loss.

Since a bright room contrast ratio indicates a ratio of an intensity of light emitted from the pixels to an intensity of

light due to the external light reflection, the bright room contrast ratio and visibility may be improved by attaching the first and second anti-reflective films **210** and **220** having a moth eye structure on the two opposite surfaces of the transparent display panel **100**, respectively.

FIG. 4 is a cross-sectional view schematically illustrating a flat panel display device **2** according to another embodiment of the present invention.

Referring to FIG. 4, the flat panel display device **2** of FIG. 4 further includes a first circular polarizer **300** interposed between the transparent display panel **100** and the first anti-reflective film **210**.

The first circular polarizer **300** may include a first quarter wave plate **310** and a first linear polarizer **320**, but the present invention is not limited thereto.

In embodiments, the first circular polarizer **300** may be formed of a combination of the linear polarizer and the phase retardation plate that may convert the incident light to circularly polarized light. For example, the first circular polarizer **300** may have a structure of sequentially stacked a quarter wave plate, a half wave plate, and a linear polarizer.

When external light is incident on the pixel area PA1 of the transparent display panel **100**, the circular polarizer **300** prevents the light from being reflected by a light-reflecting material such as a metal layer (not shown) included in the pixel area PA1 and from being emitted again to the outside.

In embodiments, when an optical axis of the first quarter wave plate **310** and an absorption axis of the first linear polarizer **320** are disposed to form an angle of about 45 degrees, the light incident from the outside becomes polarized in one direction due to the first linear polarizer **320**, and is converted to circularly polarized light after passing the first quarter wave plate **310**.

When the light converted to the circularly polarized light is reflected at the pixel area PA1, a phase of the light is shifted by about 90 degrees, and the light becomes polarized in one direction again after passing through the first quarter wave plate **310**.

In embodiments, the light incident from the outside and linearly polarized by passing through the first linear polarizer **320** is perpendicular to the light reflected and linearly polarized by passing through the first quarter wave plate **310**, and thus the reflected light may not transmit the first linear polarizer **320**. Therefore, the light incident from the outside is prevented from being reflected and emitted to the outside again.

FIG. 5 is a cross-sectional view schematically illustrating a flat panel display device **3** according to another embodiment of the present invention.

Referring to FIG. 5, the flat panel display device **3** of FIG. 5 further includes a second circular polarizer **400** interposed between the transparent display panel **100** and the second anti-reflective film **220**. The second circular polarizer **400** includes a second quarter wave plate **410** and a second linear polarizer **420**.

When the two surfaces of the transparent display panel **100** emit light, the flat panel display device **3** in accordance with the illustrated embodiment may be more effective in suppressing external light reflection from the two surfaces of the transparent display panel **100**.

FIG. 6 is a cross-sectional view schematically illustrating a flat panel display device **4** according to another embodiment of the present invention.

Referring to FIG. 6, the flat panel display device **4** of FIG. 6 includes the transparent display panel **100**, a first anti-reflective film **210'**, and a second anti-reflective film **220'**. The first anti-reflective film **210'** is disposed on the one surface

110 of the transparent display panel **100**, has a moth eye structure, and contains a light-absorbing dye that absorbs at least a part of the light having a wavelength within a range of about 350 nm to about 800 nm. The second anti-reflective film **220'** is disposed on the other surface **120** of the transparent display panel **100**, has a moth eye structure, and contains a light-absorbing dye that absorbs at least a part of the light having a wavelength within a range of about 350 nm to about 800 nm.

In embodiments, the light-absorbing dye absorbs at least a part of the light having wavelengths corresponding to a band of visible ray. In embodiments, the light-absorbing dye may absorb a wavelength within a range of about 350 nm to about 800 nm in one embodiment. In another embodiment, the light-absorbing dye may absorb a wavelength within a range of about 380 nm to about 770 nm.

In embodiments, the light-absorbing dye may include red, green, or blue pigments.

Color impression of light that is reflected from or transmitted through the flat panel display device **4** may be controlled by providing the light-absorbing dye in the first and second anti-reflective films **210'** and **220'**, and thus quality of an image realized by the flat panel display device **4** may be improved.

In embodiments, types and amount of the pigments may be appropriately combined depending on wavelength and quantity of light to be absorbed.

The light-absorbing dye is included in both of the first and second anti-reflective films **210'** and **220'** of the flat panel display device **4** of FIG. 6, but the present invention is not limited thereto, and the light-absorbing dye may be included in only one of the first and second anti-reflective films **210'** and **220'**.

FIG. 7 is a cross-sectional view schematically illustrating a flat panel display device **5** according to another embodiment of the present invention.

Referring to FIG. 7, the flat panel display device **5** of FIG. 7 further includes a first light-absorbing film **510** and a second light-absorbing film **520**. The first light absorbing film **510** is interposed between the transparent display panel **100** and the first anti-reflective film **210**. The second light-absorbing film **520** is interposed between the transparent display panel **100** and the second anti-reflective film **220**.

In embodiments, the first and second light-absorbing films **510** and **520** may absorb at least a part of the light having a wavelength within a range of about 350 nm to about 800 nm. The first and second light-absorbing films **510** and **520** are coated with or contain a light-absorbing material which includes the red, green, or blue pigments as described above.

In the flat panel display device **5** according to the current embodiment of the present invention, color impression of light that is reflected from or transmitted through the flat panel display device **5** may be controlled by controlling wavelength and quantity of light that is absorbed by the first and second light-absorbing films **510** and **520**, and thus quality of an image realized by the flat panel display device **5** may be improved.

FIG. 8 is a cross-sectional view schematically illustrating an organic light emitting display device **6** according to an embodiment of the present invention.

Referring to FIG. 8, the organic light emitting display device **6** according to an embodiment of the present invention includes a transparent display panel **600** including a transparent area TA2 which can transmit light incident on one surface **610** to the other surface **620** opposite to the one surface **610**, and a pixel area PA2 which includes a pixel including a pixel electrode **41**, an organic emission layer **42** disposed on the

pixel electrode **41**, and a counter electrode **43** disposed on the organic emission layer **42**; a first anti-reflective film **210** formed on the one surface of the transparent display panel **600** with a moth eye structure; and a second anti-reflective film **220** formed on the other surface of the transparent display panel **600** with a moth eye structure. In embodiments, the transparent area TA2 can be interposed between two neighboring pixel areas.

In embodiments, the transparent display panel **600** includes a thin film transistor **20**, a capacitor **30**, and an organic light emitting diode **40**.

In one embodiment, the transparent display panel **600** includes a transparent substrate **10** formed of a transparent insulating substrate including glass, quartz, ceramic, or plastic. The thin film transistor **20** disposed on the transparent substrate **10** includes an active layer **21**, a gate electrode **23**, and source and drain electrodes **25a** and **25b**.

The active layer **21** may be formed of a semiconductor material such as amorphous silicon or polysilicon, but is not limited thereto, and may be formed of an oxide semiconductor. The active layer **21** may include a channel area **21c** and source and drain areas **21a** and **21b** that are doped with ion impurities at outer sides of the channel area **21c**.

The gate electrode **23** is disposed on the active layer **21**, and a gate insulating layer **12** is interposed between the active layer **21** and the gate electrode **23**. In embodiments, the gate electrode **23** may include one or more metals selected from Al, Pt, Pd, Ag, Mg, Au, Ni, Nd, Ir, Cr, Li, Ca, Mo, Ti, W, and Cu, and may be formed in a single layer or multi layers.

An interlayer insulating layer **14** is disposed on the gate electrode **23**, and the source and drain electrodes **25a** and **25b**, which are respectively connected to the source and drain areas **21a** and **21b**, are disposed with the interlayer insulating layer **14** therebetween.

The source and drain electrodes **25a** and **25b** includes one or more metals selected from Al, Pt, Pd, Ag, Mg, Au, Ni, Nd, Ir, Cr, Li, Ca, Mo, Ti, W, and Cu, and may be formed in a single layer or multi layers.

A planarization layer **16** including via holes, which electrically connect the pixel electrode **41** and one of the source and drain electrodes **25a** and **25b**, is disposed on the source and drain electrodes **25a** and **25b**.

The capacitor **30** includes a lower electrode **33** formed of the same material with the gate electrode **23** and an upper electrode **35** formed of the same material with the source and drain electrodes **25a** and **25b**.

The organic light emitting diode **40** is disposed on the planarization layer **16**, and the organic light emitting diode **40** includes the pixel electrode **41**, the organic emission layer **42**, and the counter electrode **43** that are sequentially disposed. In embodiments, a pixel defining layer **50** is disposed to cover an edge of the pixel electrode **41**.

According to the current embodiment, the pixel electrode **41** may be an anode, and the counter electrode **43** may be a cathode. However, the present invention is not limited thereto, and the pixel electrode **41** may be a cathode, and the counter electrode **43** may be an anode.

The pixel electrode **41** included in the organic light emitting diode **40** according to the current embodiment may be a reflective electrode. The pixel electrode **41** may include a reflecting film formed of Ag, Mg, Al, Pt, Pd, Au, Ni, Nd, Ir, Cr, or a compound thereof, and a transparent or semitransparent electrode layer formed on the reflecting film.

The transparent or semitransparent electrode layer may include at least one selected from the group consisting of indium tin oxide (ITO), indium zinc oxide (IZO), zinc oxide

(ZnO), indium oxide (In_2O_3), indium gallium oxide (IGO), and aluminum zinc oxide (AZO).

The counter electrode **43** disposed opposite to the pixel electrode **41** may be a transparent electrode and may be formed of a metal thin layer with a small work function including Li, Ca, LiF/Ca, LiF/Al, Al, Ag, Mg, or a compound thereof. Also, an auxiliary electrode layer or a bus electrode as a material for forming the transparent electrode of ITO, IZO, ZnO, or In_2O_3 may be further formed on the metal thin layer.

Thus, in embodiments, the counter electrode **43** can transmit the light emitted from the organic light emission layer **42**.

The organic emission layer **42** is interposed between the pixel electrode **41** and the counter electrode **43**, and the organic emission layer **42** may be formed of a low molecular weight organic material or a high molecular weight organic material.

An interlayer such as a hole transport layer (HTL), a hole injection layer (HIL), an electron transport layer (ETL), or an electron injection layer (EIL) may be selectively interposed between the pixel electrode **41** and the counter electrode **43** as well as the organic emission layer **42**.

The light emitted from the organic emission layer **42** may be a top emission type that is directly or reflected by the pixel electrode **41** constructed of the reflective electrode and emitted to the counter electrode **43**.

The transparent display panel **600** according to embodiments includes the transparent area TA2 and the pixel area PA2. The gate electrode **23** and the source and drain electrodes **25a** and **25b** of the thin film transistor **20**, the lower electrode **33** and the upper electrode **35** of the capacitor **30**, and the pixel electrode **41** of the organic light emitting diode **40** are formed of a metal which may reflect the incident light.

In embodiments, the thin film transistor **20**, the capacitor **30**, and the organic light emitting diode **40** are formed in the pixel area PA2, and are not formed in the transparent area TA2. In some embodiments, the gate insulating layer **12**, the interlayer insulating layer **14**, the planarization layer **16**, and the pixel defining layer **50** that are commonly disposed on the pixel area PA2 and the transparent area TA2 are all formed of a transparent insulating layer, and the counter electrode **43** that is formed as a common electrode may be made of a transparent material.

In embodiments, a ratio of an area of the transparent area TA2 to that of the entire transparent display panel **600** may be controlled or adjusted within a range from about 20 to about 90%.

The transparent display panel **600** may be sealed by a sealing substrate **60** to protect the organic light emitting diode **40**, and the sealing substrate **60** may be a transparent substrate.

In embodiments, the first and second anti-reflective films **210** and **220** having a moth eye structure are disposed on the two surfaces **610** and **620** of the transparent display panel **600** of the organic light emitting display device **6**, respectively. A structure and function of the first and second anti-reflective films **210** and **220** are same as described above.

FIGS. **9** through **11** are cross-sectional views schematically illustrating a method of manufacturing the flat panel display device of FIG. **1**

Referring to FIG. **9**, in embodiments, the transparent display panel **100** including the transparent area TA1 is formed. The transparent display panel **100** includes the transparent area TA1 for transmitting light and the pixel area PA1 for forming an image, and the pixel area PA1 may include the organic emission layer or the liquid crystal cell.

Referring to FIG. 10, the first anti-reflective film 210 having a moth eye structure is disposed on the one surface 110 of the transparent display panel 100.

A moth eye structure includes a plurality of projections that are respectively spaced at an interval equal to or less than the wavelength of a visible ray, and does not reflect light regardless of an incident angle or wavelength of light. The projections may be in the form of a quadrangular pyramid or a circular cone.

Referring to FIG. 11, the second anti-reflective film 220 having a moth eye structure is disposed on the other surface 120 of the transparent display panel 200.

A detailed description of each of the elements is described above, and thus their description will be omitted for brevity.

As described above, the flat panel display device, the organic light emitting display device, and the method of manufacturing the flat panel display device according to the one or more of the above embodiments of the present invention may improve a bright room contrast and visibility by suppressing external light reflection by disposing the anti-reflective films with a moth eye structure on one or two surfaces of the transparent display panel of the flat panel display device.

Also, quality of an image formed by the flat panel display device may further be improved by providing the anti-reflective films including dye that absorbs light of a particular band of wavelengths or by additionally inserting a light absorbing film to the display panel.

Moreover, a luminance efficiency of the light may be increased.

The elements in the drawings may be described exaggerated or minimized for clarity, and thus the present invention is not limited to the size or shape of the elements in the drawings. While embodiments of the present invention have been particularly shown and described with reference to the drawings, it will be understood by those of ordinary skill in the art that various changes in form and details may be made therein without departing from the spirit and scope of the present invention as defined by the following claims.

What is claimed is:

1. A flat panel display device comprising:

a transparent display panel comprising a front transparent substrate, a back transparent substrate and a pixel array interposed between the front and back transparent substrates;

the pixel array comprising a plurality of pixels and a plurality of transparent areas, each transparent area having sufficient transparency to transmit visible light such that light beams incident on the front transparent substrate pass through one or more of the transparent areas of the pixel array and further pass through the back transparent substrate;

a first anti-reflective film which is formed over a surface of the front transparent substrate and comprises a moth eye structure;

a second anti-reflective film which is formed over a surface of the back transparent substrate and comprises a moth eye structure, wherein the second anti-reflective film is configured to inhibit reflection, back toward the front transparent substrate, of light beams that have passed through one or more of the transparent areas and reached the second anti-reflective film; and

a first light-absorbing film covering the transparent areas when viewed in a direction perpendicular to a major surface of the front transparent substrate, the first light-absorbing film being interposed between the transparent display panel and the first anti-reflective film, the first

light-absorbing film being configured to absorb at least a portion of light having a wavelength within a range of about 350 nm to about 800 nm.

2. The flat panel display device of claim 1, wherein the first and second anti-reflective films comprise a plurality of projections, each of which is in the form of a quadrangular pyramid or a circular cone.

3. The flat panel display device of claim 1, wherein the moth eye structure comprises a plurality of projections that are respectively spaced at an interval equal to or less than the wavelength of a visible ray.

4. The flat panel display device of claim 1 further comprising a first circular polarizer interposed between the transparent display panel and the first anti-reflective film.

5. The flat panel display device of claim 1 further comprising a second circular polarizer interposed between the transparent display panel and the second anti-reflective film.

6. The flat panel display device of claim 1 further comprising a second light-absorbing film, which is interposed between the transparent display panel and the second anti-reflective film and configured to absorb at least a portion of light having a wavelength within a range of about 350 nm to about 800 nm.

7. The flat panel display device of claim 1, wherein the first anti-reflective film comprises a light-absorbing dye, which absorbs at least a part of light having a wavelength within a range of about 350 nm to about 800 nm.

8. The flat panel display device of claim 1, wherein the second anti-reflective film comprises a light-absorbing dye, which is configured to absorb at least a part of light having a wavelength within a range of about 350 nm to about 800 nm.

9. An organic light emitting display device comprising:

a transparent display panel comprising a front transparent substrate, a back transparent substrate and a pixel array interposed between the front and back transparent substrates;

the pixel array comprising a plurality of pixels and a plurality of transparent areas, at least one of the plurality of pixels comprising a pixel electrode, an organic emission layer disposed over the pixel electrode, and a counter electrode disposed over the organic emission layer, at least one of the plurality of transparent areas having sufficient transparency to transmit visible light such that light beams incident on the front transparent substrate pass through one or more of the transparent areas of the pixel array and further pass through the back transparent substrate;

a first anti-reflective film placed over a surface of the front transparent substrate and comprising a moth eye structure;

a second anti-reflective film placed over a surface of the back transparent substrate and comprising a moth eye structure, wherein the second anti-reflective film is configured to inhibit reflection, back toward the front transparent substrate, of light beams that have passed through one or more of the transparent areas and reached the second anti-reflective film; and

a first light-absorbing film covering the transparent areas when viewed in a direction perpendicular to a major surface of the front transparent substrate, the first light-absorbing film being interposed between the transparent display panel and the first anti-reflective film, the first light-absorbing film being configured to absorb at least a portion of light having a wavelength within a range of about 350 nm to about 800 nm.

10. A method of manufacturing a flat panel display device comprising:

11

providing a transparent display panel comprising a front transparent substrate, a back transparent substrate and a pixel array interposed between the front and back transparent substrates, the pixel array comprising a plurality of pixels and a plurality of transparent areas, each transparent area having sufficient transparency to transmit visible light such that light beams incident on the front transparent substrate pass through one or more of the transparent areas of the pixel array and further pass through the back transparent substrate;

forming, over the transparent areas when viewed in a direction perpendicular to a major surface of the front transparent substrate, a first light-absorbing film configured to absorb at least a portion of light having a wavelength within a range of about 350 nm to about 800 nm;

forming a first anti-reflective film over the first light-absorbing film, wherein the first anti-reflective film comprises a moth eye structure; and

forming a second anti-reflective film over a surface of the back transparent substrate, wherein the second anti-reflective film comprises a moth eye structure.

11. The method of claim 10, wherein the forming of the first and second anti-reflective films comprises forming a plurality of projections of the first and second anti-reflective films, each of the plurality of projections being in the form of a quadrangular pyramid or a circular cone.

12

12. The method of claim 10, wherein the forming of the first and second anti-reflective films comprises forming the moth eye structure comprising a plurality of projections that are respectively spaced at an interval equal to or less than the wavelength of the visible ray.

13. The method of claim 10, wherein the method further comprises forming a first circular polarizer before the forming of the first anti-reflective film.

14. The method of claim 10, wherein the method further comprises forming a second circular polarizer before the forming of the second anti-reflective film.

15. The method of claim 10, wherein the method further comprises forming a second light-absorbing film configured to absorb at least a portion of light having a wavelength within a range of about 350 nm to about 800 nm before the forming of the second anti-reflective film.

16. The method of claim 10, wherein the first anti-reflective film comprises a light-absorbing dye, which is configured to absorb at least a part of light having a wavelength within a range of about 350 nm to about 800 nm.

17. The method of claim 10, wherein the second anti-reflective film comprises a light-absorbing dye, which is configured to absorb at least a part of light having a wavelength within a range of about 350 nm to about 800 nm.

* * * * *

专利名称(译)	平板显示装置，有机发光显示装置和制造平板显示装置的方法		
公开(公告)号	US8841836	公开(公告)日	2014-09-23
申请号	US13/677123	申请日	2012-11-14
[标]申请(专利权)人(译)	三星显示有限公司		
申请(专利权)人(译)	三星DISPLAY CO. , LTD.		
当前申请(专利权)人(译)	三星DISPLAY CO. , LTD.		
[标]发明人	KIM SANG HO BAE JAE WOO LEE HUN JUNG		
发明人	KIM, SANG-HO BAE, JAE-WOO LEE, HUN-JUNG		
IPC分类号	H01L51/52 H05B33/02 G02B1/11 G02B5/30 H05B33/12		
CPC分类号	H05B33/12 G02B5/3025 G02B1/11 G02B1/118 G02B5/223 G02F1/133502 H01L27/322 H01L27/326 H01L51/5281 H01L51/5284		
审查员(译)	罗利, DONALD		
优先权	1020120044671 2012-04-27 KR		
其他公开文献	US20130285539A1		
外部链接	Espacenet USPTO		

摘要(译)

一种平板显示装置，包括透明显示板，该透明显示板包括透射区域，该透明区域将入射在透明显示板的一个表面上的光透射到与该一个表面相对的另一个表面上第一抗反射膜，形成在透明显示面板的一个表面上，并具有蛾眼结构；第二抗反射膜，形成在透明显示板的另一表面上，并具有蛾眼结构。

